

Control of Structural Seismic Damage in Prefabricated Reinforced Concrete Frames through Hybrid-Selfcentering Connections

Juan Marcus¹, Rodrigo Thiers²

1. Department of Civil and Environmental Engineering, Universidad del Bío-Bío, Avda. Collao 1202, Concepción, Chile.

2. Department of Civil Works, Universidad Técnica Federico Santa María, Avda. España 1680, Valparaíso, Chile.

Abstract: Current seismic design philosophy of industrial structures in Chile aims at the protection of life and continuity of operation in the industry. The compliance with these requirements allows controlling structural damage based on resistance criteria, without detecting the failure mode or specifying its location in the event of a major seismic event. In this paper, we discuss the application of an innovative technique for controlling the structural damage in prefabricated reinforced concrete frames, which are founded on granular soils. This technique is applied in the construction of the Forest and Paper Pulp Plant Concepción. This is done by incorporating hybrid post-tensioned joints in precast columns of the project, and this approach aims to control energy dissipation in the union and maintain the initial stiffness of the system. Using a nonlinear dynamic analysis with 2D Ruaumoko software, potential performance in traditional design versus innovative design is compared. The analysis is performed for various Chilean representative seismic records and different types of soils. The results indicate that the structure with the traditional design could suffer displacement in the roof of the order of 40 cm, moving heavily into the inelastic range, with residual deformations and concentrating the damage generation of plastic hinges at the ends of the columns and some beams not designed for ductility. In contrast, the use of self-centering hybrid joints causes the structure to recover its original position, without the presence of remnant deformations.

Key words: precast concrete; hybrid post-tensioned joints; seismic damage

1. Introduction

The current seismic design concept for industrial structures in Chile targets life protection and operational continuity in industry. Meeting these requirements does not guarantee that structural damage will not occur in major seismic events. This situation has led to legal disputes between investors, construction companies, and structural engineering consulting firms due to their different expectations for performance and structural damage.

Among the most commonly used types of buildings in industrial structures, prefabricated reinforced concrete gantry cranes stand out. Its assembly speed, competitive cost, excellent fire resistance, and building versatility make it an effective alternative solution in the aforementioned context. However, various theories and ground studies have shown that such structures may leave residual damage and deformation after major earthquake events occur. When these structures are built

on loose or soft soil foundations, this situation becomes more pronounced, increasing the likelihood of legal disputes and additional costs for structural repair and restoration.

Figure 1 shows some examples of typical seismic damage in precast reinforced concrete structures reported in Turkey (Saatcioglu et al., 2001; Posada and Wood, 2002; Sezen et al., 2006; Arslan et al., 2006). The aforementioned cases are complemented by damage reported in China (Zhao et al., 2009), and New Zealand (Kam et al., 2010, 2011) in similar structural typologies.



Figure 1. Seismic damage patterns present in precast industrial reinforced concrete columns in Turkey; a) Concentrated flexural patella damage in column base (Posada and Wood, 2002), b) Concentrated damage in column base with plinth type foundation, c) Flexural patella damage distributed over 800 mm of column height and d) Severe concentrated flexural buckling damage at column base (Saatcioglu et al., 2001).

As shown in Figure 1, due to the strong inelastic demand for the cross-section, typical damage to these structures is concentrated at the bottom of the prefabricated columns. These damages are quite unacceptable as they hinder the sustained operation of the industry and may even lead to structural collapse.

With the evidence mentioned above, in the last 15 years, a series of initiatives have been carried out to develop design techniques for controlling damage in precast reinforced concrete structures (Pampanin, 2005). One of the first initiatives was a ductile dry-joint system called U.S. PRESS (PREcast Seismic Structural System), which was tested at the University of California (Priestley, 1991, 1996; Priestley et al., 1999), featuring post-tensioned unbonded cables. The inelastic demand is accommodated within the connection, through the opening and closing of an existing gap, in a rocking-type motion. As a

result, a configuration was achieved that can develop inelastic displacements, limiting structural damage and ensuring full self-centering capability. The hysteretic behavior of the joint is essentially nonlinear-elastic, with reduced energy dissipation capability.

As an improvement to the press system, Stanton et al. (1997) developed the concept of hybrid joints, which is based on the use of unbonded post-tensioned steel strands and non-prestressed ductile steel longitudinal bars. This combination provides self-centering and energy dissipation characteristics. Under moderate seismic action, the classic plastic hinge mechanism is replaced by a controlled rocking mechanism at the critical interface, which does not cause damage to the structural elements. Although post-tensioned steel bars provide a self-centering restorative effect, ductile steel bars act as energy dissipaters to absorb the effects of seismic loads. Additionally, to prevent premature fracture of these ductile steel bars, they are given a very small length near the mixed joint, enclosed in a sheath without sticking.

This particular self-centering dissipating mechanism of hybrid joints is generally described by a flag-shaped hysteretic behavior. Figure 2 schematizes the operation principle of self-centering hybrid joints.

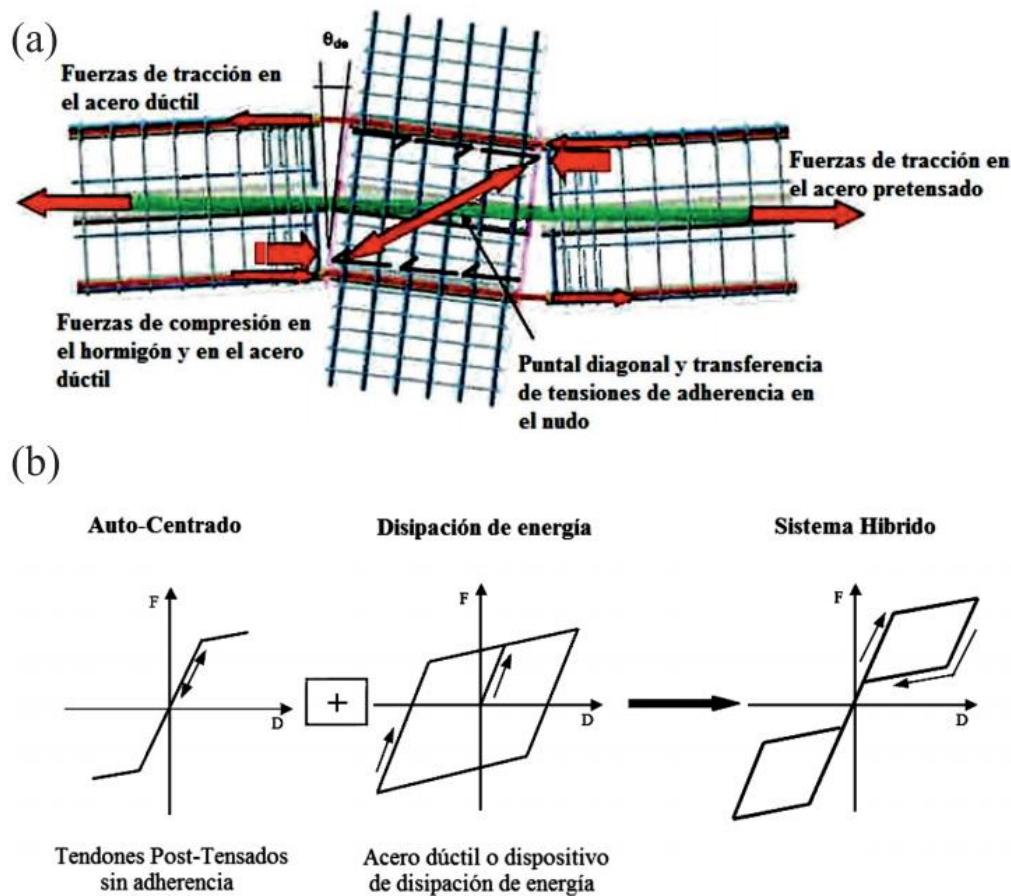

Figure 2. Schemes of operation of self-centering hybrid joints. a) Schematic of internal forces in beam-column joint and b) constitutive models with flag-shaped hysteretic cycles (Buchanan et al., 2011).

This article explains the industrial project of incorporating a self-centering hybrid joint system into prefabricated reinforced concrete gantry cranes. These structures were established on a deep foundation of loose sand in the city of Corona, Chile. Through nonlinear numerical analysis, the response of structures with and without mixed nodes was compared with the Chilean earthquake acceleration map. Finally, the construction details of the solution, possible failure mechanisms, and potential comparative advantages in damage control were discussed. Through this approach, the aim is to promote the dissemination of this innovative system in high seismic activity areas.

2. Materials and Methods

2.1 Characterization of the study project with hybrid joints

The project consists of a 1920 m² industrial building, consisting of post-tensioned precast concrete frames, with a maximum column height of 18.5 m, located in a coastal area of high seismicity and founded on a loose sandy soil with an average relative density of 50%. This building is called M3A, and the plan and cross-sectional views of the project are shown in Figure 3.

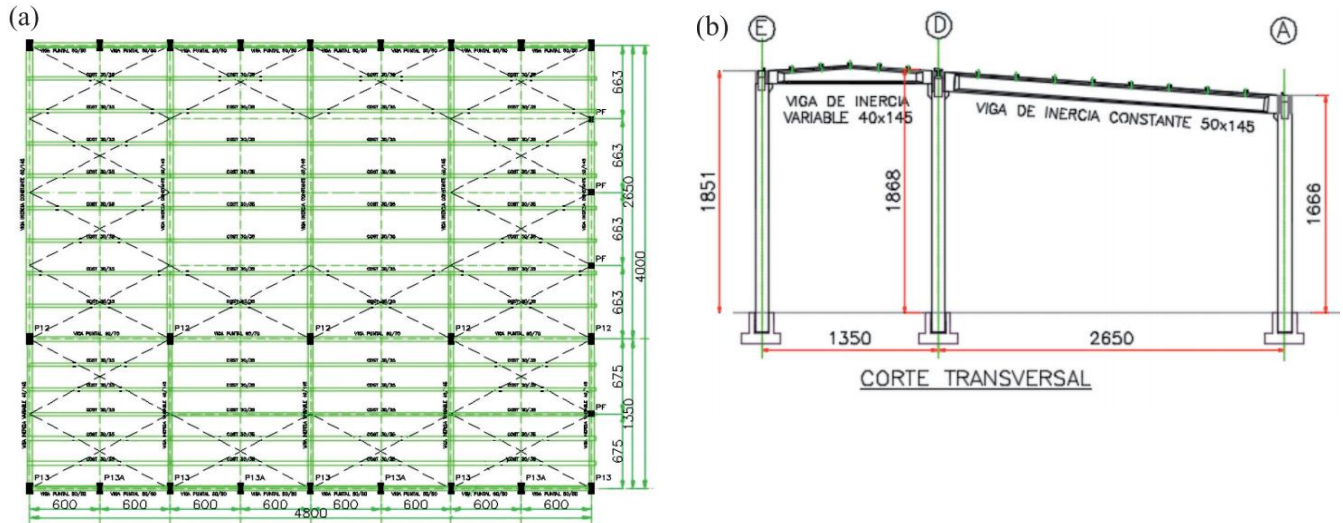

Figure 3. Diagrams in a) plan and b) elevation of the project (dimensions in cm).

Originally, the project envisaged a system of rigid, cast-in-place concrete connections (wet connections), with columns and post-tensioned beams, ranging in size from 40 cm wide to 145 cm high. However, the seismic design review suggested the inclusion of hybrid connections at the column ends, in order to minimize structural damage and avoid possibly brittle failures at the nodes beyond the hybrid connections, which remain rigid and cast-in-place. Figure 4 shows some construction details of the columns and their hybrid connections.

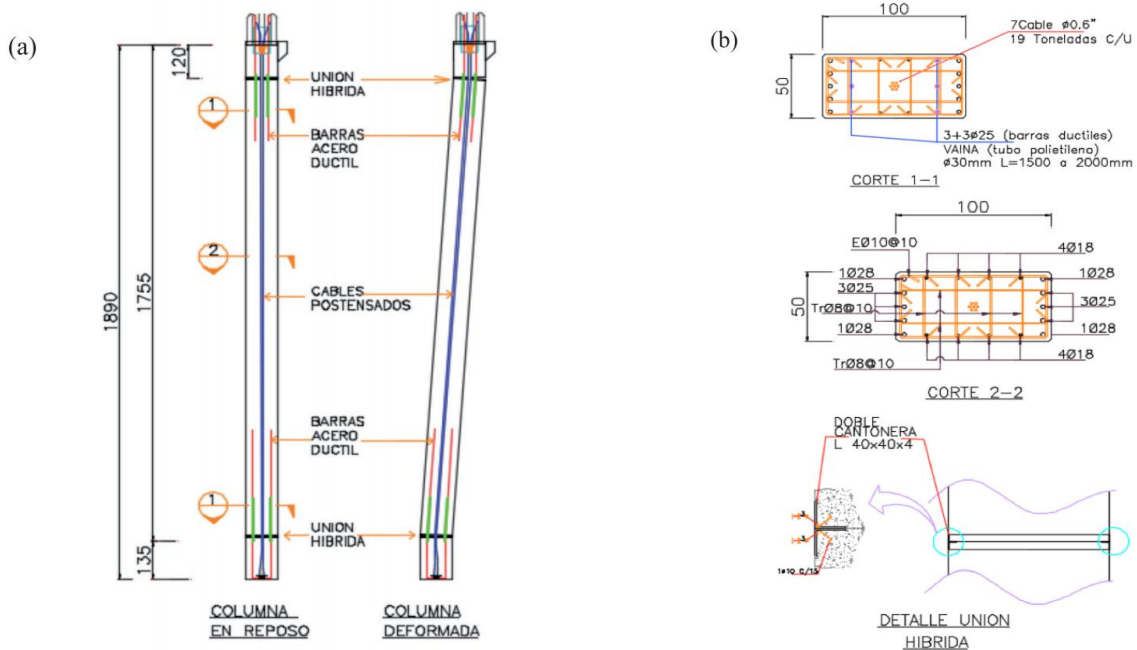

Figure 4. Construction details of columns with hybrid connections, a) E-axis column and kinematic diagram and b) cross sections and details

On the other hand, Figure 5 shows some images of the project in the construction stage.



Figure 5. (a) Construction and assembly of structural elements, (b) Hybrid connection at top and (c) Bottom edge of a column.

2.2 Analysis of the structure with hybrid joints

To evaluate the damage level of the project with and without hybrid connections, nonlinear numerical simulations of the portal frames were performed. The analyses were performed with the Ruaumoko 2D program (Carr, 2004). Figure 6, complemented by Table 1, shows one of the analysis models, with their respective critical sections, located at the post-tensioned connections in the columns.

Table 1. Nomenclature of the elements used in the model shown in Figure 6

| Elements | Description |
|----------------|--|
| 1-3-5-10-12-14 | Rotational spring: 7 wires 0.6" post-tensioned (bilinear elastic) |
| 2-4-6-11-13-15 | Rotational spring: special ductile steel heatsink 3+3 ϕ 25 (bilinear inelastic) |
| 7-8-9-16-17-18 | Column 50 \times 100 cm (elastic linear) |
| 19 | Variable inertia beam (linear elastic) |
| 20 | Constant inertia beam (linear elastic) |

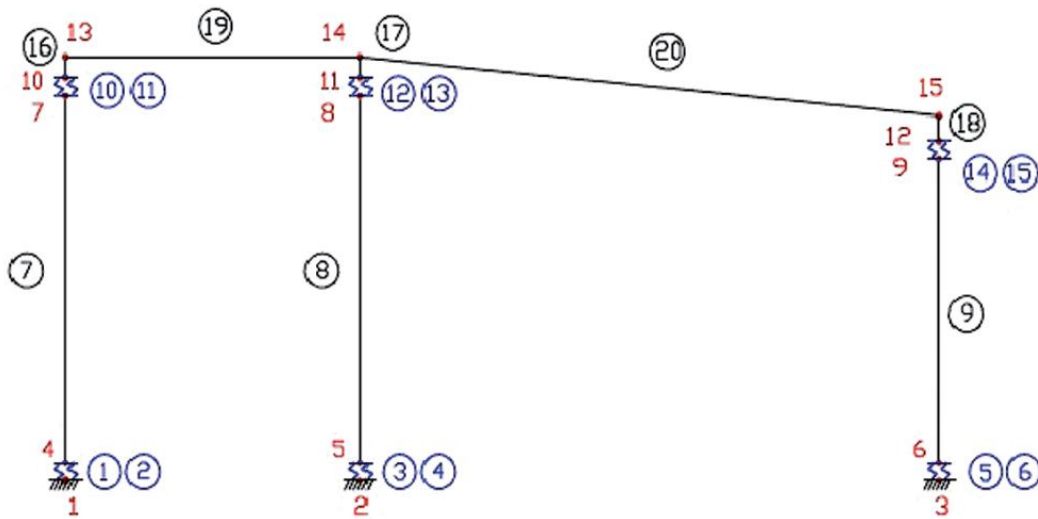

Figure 6. Typical cross-sectional framework analysis model.

The post-tensioned cables and the ductile steel bars of the hybrid connection were included in the analysis with rotational springs in parallel, following the hysteretic laws and the physical-conceptual models, as shown in Figure 7.

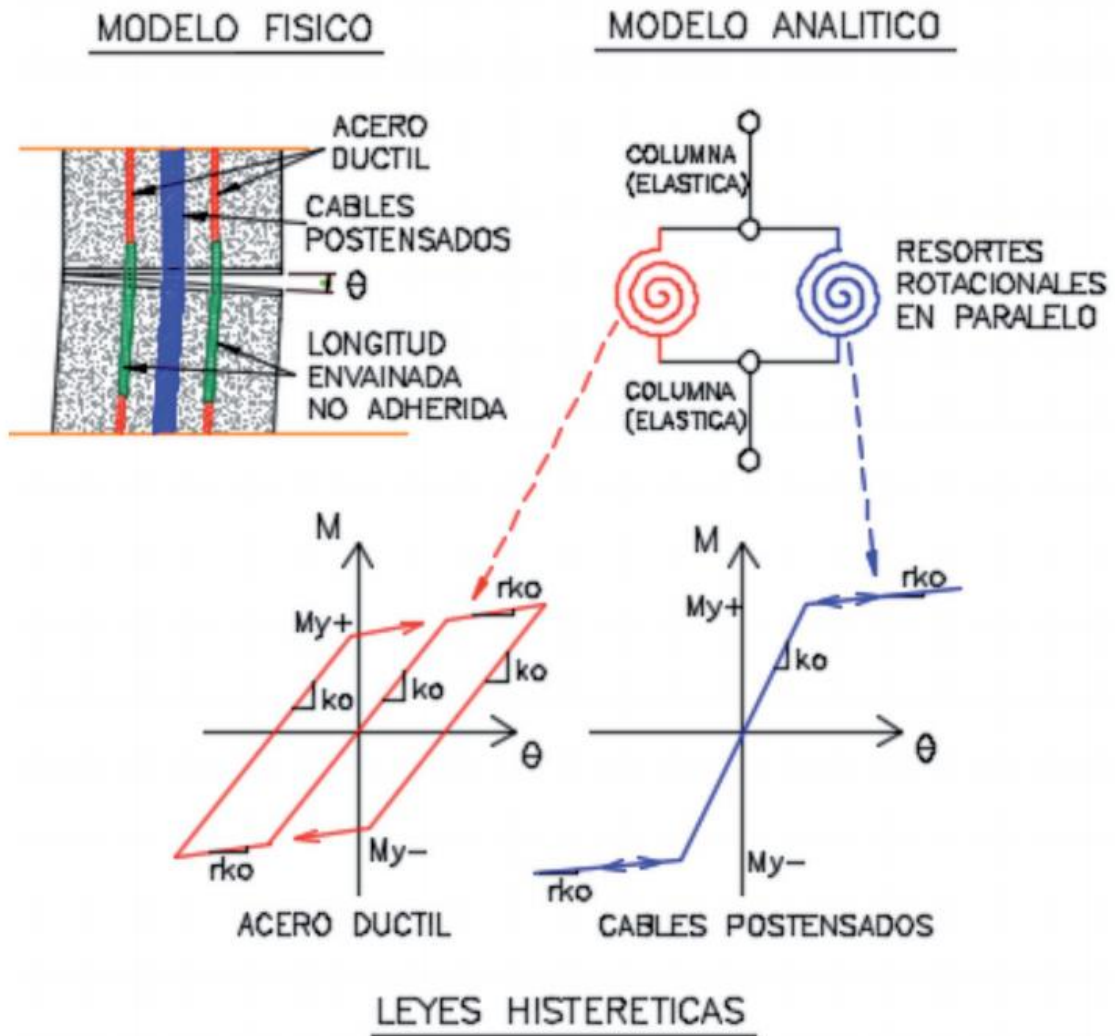

Figure 7. Physical, analytical model and hysteretic laws of ductile special steel bars (heatsinks) and post-tensioned cables.

The hysteretic laws shown in Figure 7 correspond to an inelastic bilinear law for ductile steel and an elastic bilinear law for post-tensioned wires. Table 2 shows the values of the parameters used, where K_0 is the elastic rotational stiffness, r is the ratio between the post-flow rotational stiffness and the elastic rotational stiffness and M_y is the creep bending moment. For their determination, the recommendations proposed by Celik and Sritharan (2004) were followed.

Table 2. Parameters used in hysteretic laws

| | K_0 (Tm/rad) | r | M_y (Tm) |
|-----------------------|----------------|-------|------------|
| Ductile steel | 37110 | 0.015 | 37.11 |
| Post-tensioned cables | 74096 | 0.004 | 74.10 |

As a preliminary evaluation of the modeling strategy, a two-way incremental (push-pull) analysis was performed, applying a history of roof displacements, as shown in Figure 8.

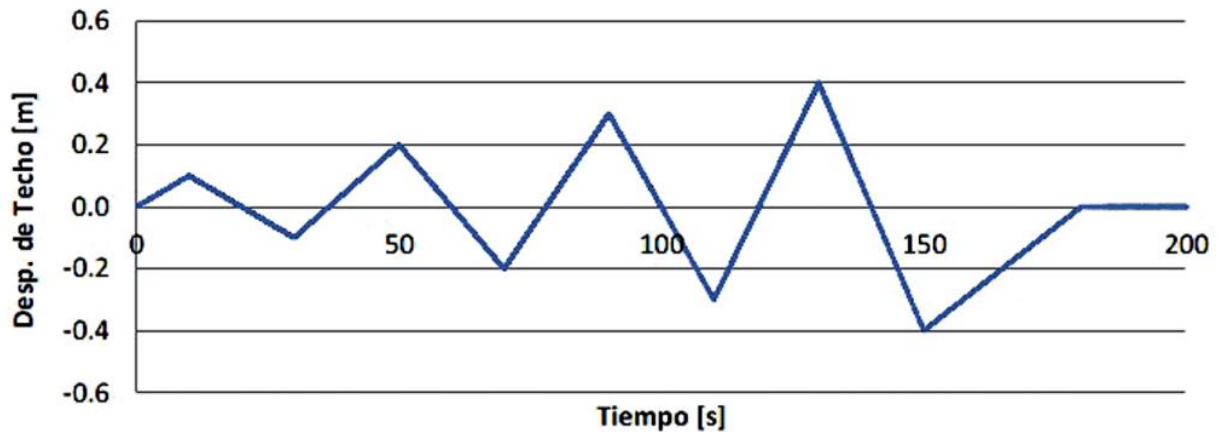

Figure 8. Displacement history applied to preliminary model.

The preliminary result shown in Figure 9 confirms that the model is capable of representing the flag-type response that characterizes these joints. Thus, it is possible to perform more detailed time-history analyses, using accelerograms that are considered representative of the local seismic conditions.

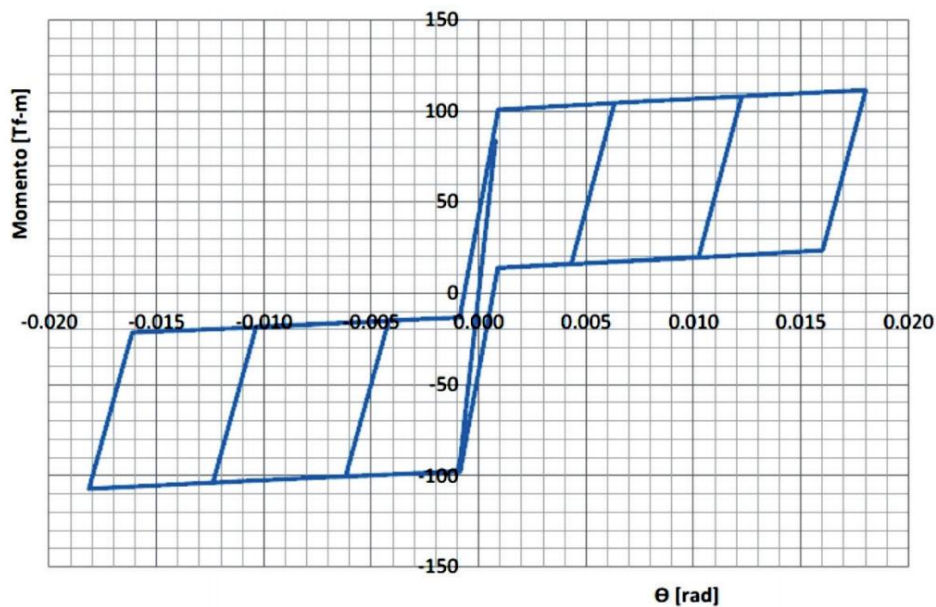

Figure 9. Moment-rotation diagram obtained in one of the hybrid joints at the lower edge of the columns.

2.3 Analysis of the original structure without hybrid joints

In order to compare structural damage and evaluate the effectiveness of the proposed solution, it is necessary to model and analyze the original structure without mixed nodes. This was achieved through nonlinear dynamic analysis using the Ruaumoko 2D program (Thiers, 2014). The transverse frame model of the ship is similar to Figure 6, but there are no hybrid joints. In this way, three columns, variable inertia beams, and constant inertia beams were considered.

To model the nonlinearity of the structure, it is assumed that the critical part is located at the end of the element and the node has sufficient strength to allow the critical part to flow before the node fails. For beams and columns, Giberson type plastic elements concentrated at their ends were used (Sharpe, 1974), with rotation concentrated at the ends of the elements. Figure 10 shows the conceptual architecture of such elements.



Figure 10. Giberson-type element for modeling nonlinearity in original structure without hybrid junctions.

In this case, Clough's (1966) hysteresis law was used, shown in Figure 11, which corresponds to the modified Takeda's law, with parameters α and β equal to zero. Since reinforced concrete elements have low post-creep stiffness, a value of r equal to 1% was used.

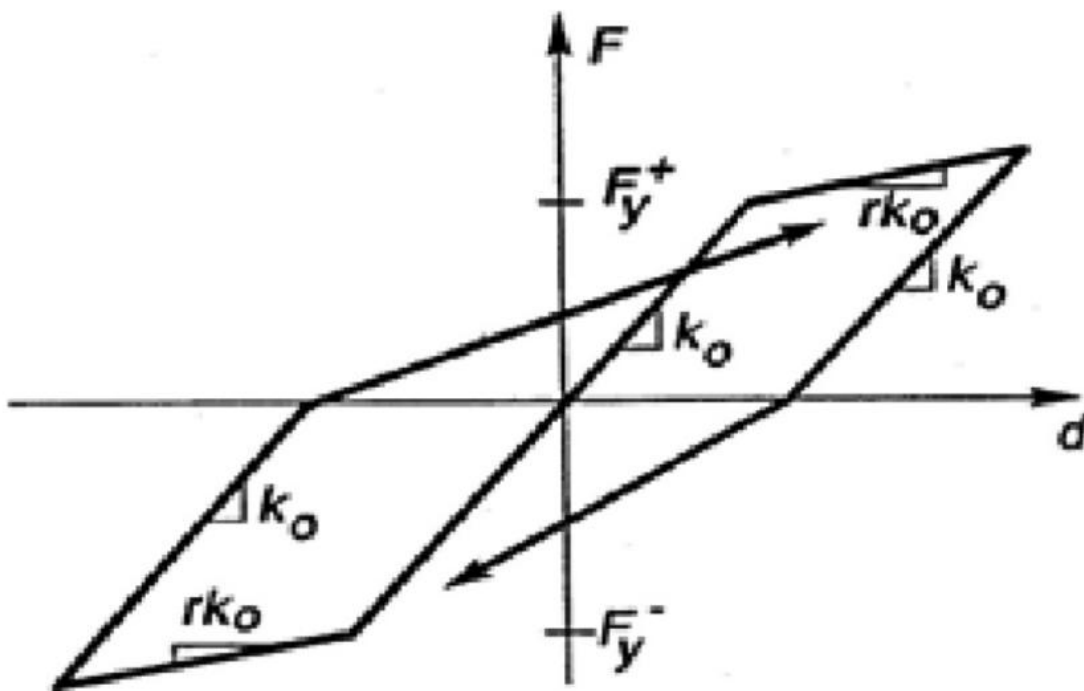

Figure 11. Clough hysteresis law for nonlinear modeling of reinforced concrete components (in the original case without mixed nodes).

3. Results and Discussion

The nonlinear analysis was performed using the seismic record obtained in Concepción in 2010, which is depicted in Figure 12. This analysis was conducted under conditions of local seismicity and soil type similar to those at the project site. Both soils correspond to Bío Bío sands, loose at the surface with relative densities in the order of 50%. Additionally, the distance between the project structure and the accelerographic station is approximately 20 km.

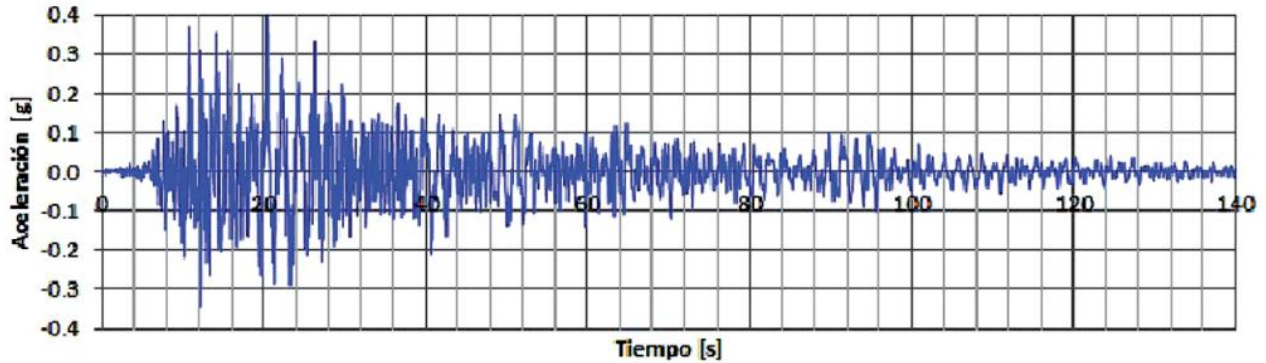

Figure 12. Accelerogram of Concepción center station, February 27, 2010, orientation 60° with respect to north (Boroschek et al, 2010).

3.1 Model without hybrid joints

As a first step, an analysis of the original structure without hybrid joints was performed. Figure 13 shows the lateral displacement response in the roof calculated for the record shown in Figure 12.

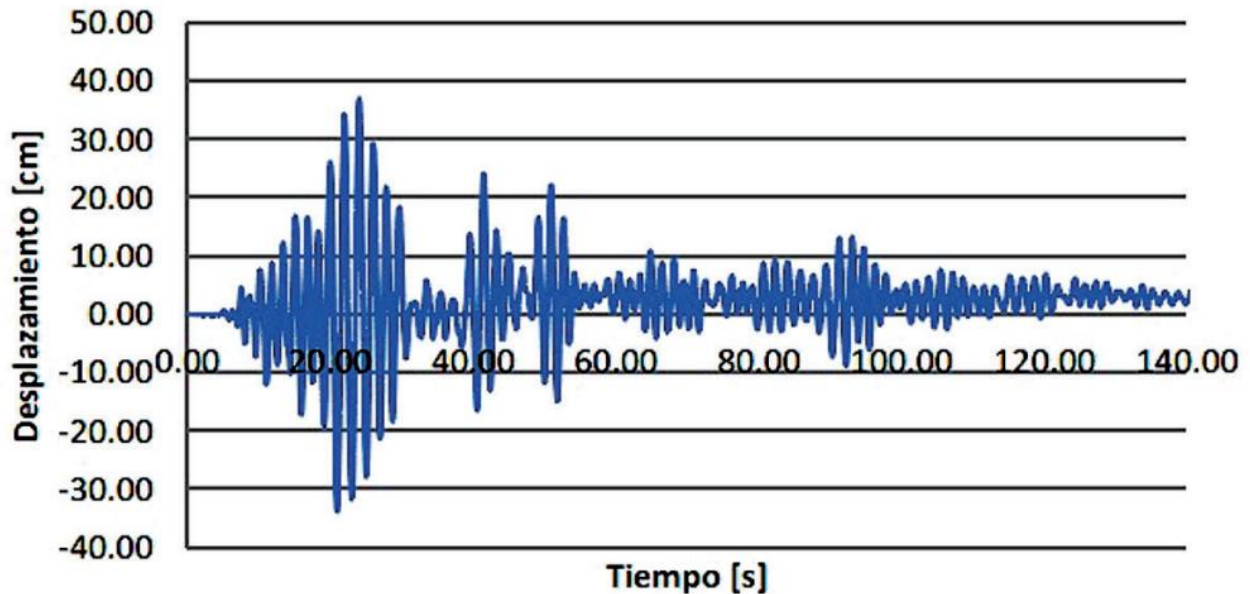

Figure 13. Lateral displacement history in the roof (without hybrid joints).

From Figure 13, it can be seen that the displacement at the top of the gantry without mixed joints reaches 37 cm. This level of displacement is important as it is related to joint damage and the presence of potentially fragile faults that cannot be located using force based design methods. In addition, preventive measures must be taken on the components horizontally connected to the ship to maintain this level of deformation. In addition, residual displacement of about 3 cm was observed. Figure 14 shows the bending moment curvature plot obtained on a foundation of prefabricated columns.

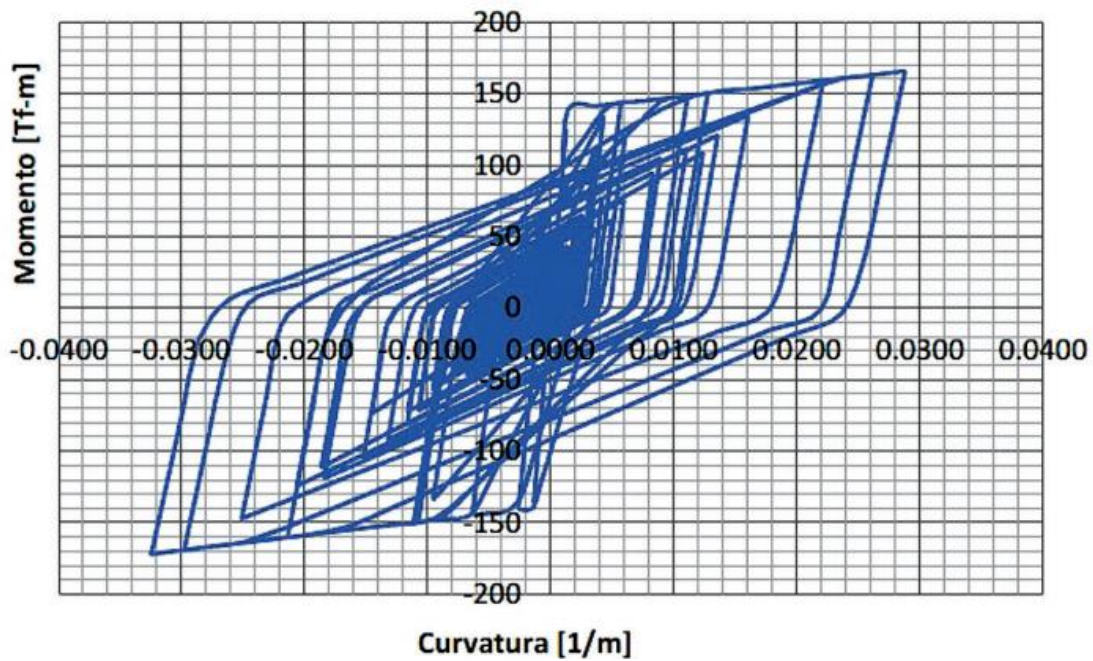

Figure 14. Moment-curvature diagram for column with hybrid joints (lower end).

The results observed in Figure 14 show strong intrusion within the nonlinear range, and the prefabricated column suffered significant damage without a mixed joint. The maximum curvature achieved is approximately 0.0324 m^{-1} . Therefore, it must be appropriately limited, given ductility and strengthened nodes.

Figure 15 shows the most needed part and the possible mechanism of gantry collapse. Based on these results, it is recommended to provide limitations in the nodes and components where plastic labels are expected to be generated. In addition, it is necessary to provide detailed instructions on cooling to avoid fragile faults and attempt to locate damage in predetermined critical parts. These suggestions are difficult to implement with the initial constructive solutions. Analysis of traditional design indicates that critical parts are expected to be damaged, with steel having a unit elongation of up to 4%.

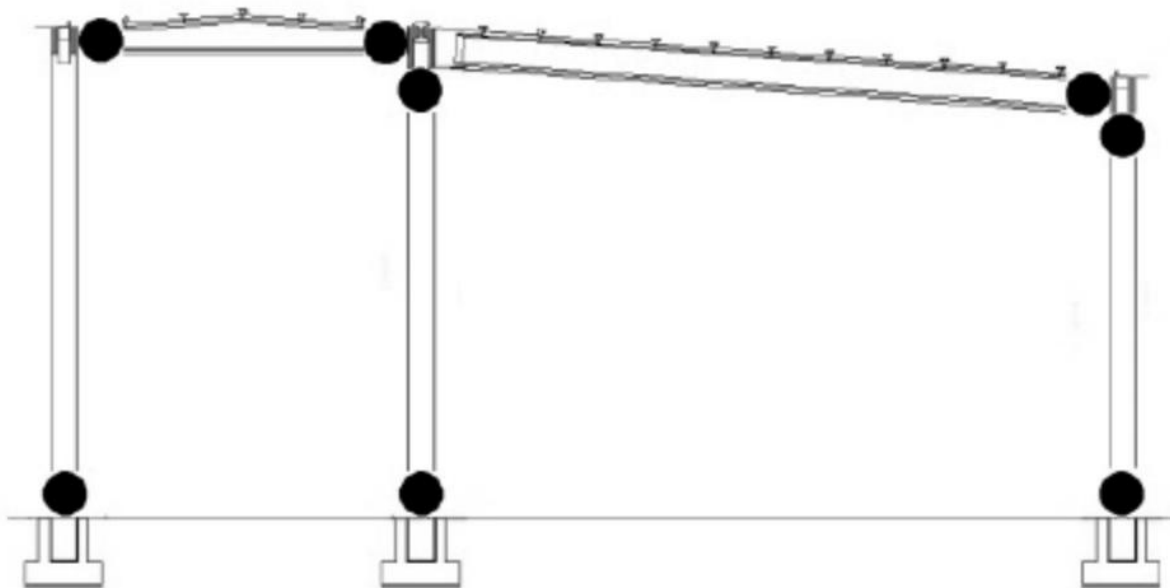

Figure 15. Possible collapse mechanism in the gantry designed using traditional methods.

3.2 Model with hybrid joints

The type of damage expected suggests the need to control its effects and limit the remaining displacements in the structure. Thus, a system of hybrid joints in the precast columns emerges as an adequate strategy to achieve these objectives. This is due to the possibility of this system to concentrate the damage in the openings and dissipate the energy with the bars devoid of adhesion in a span, avoiding concentrations of unit elongations in the steel. The design of these connections was made according to the recommendations of ACI T1.2-03 (2003).

Figure 16 shows the lateral displacement in the roof, obtained for the model with hybrid joints, subjected to the Concepción 2010 longitudinal seismic record.

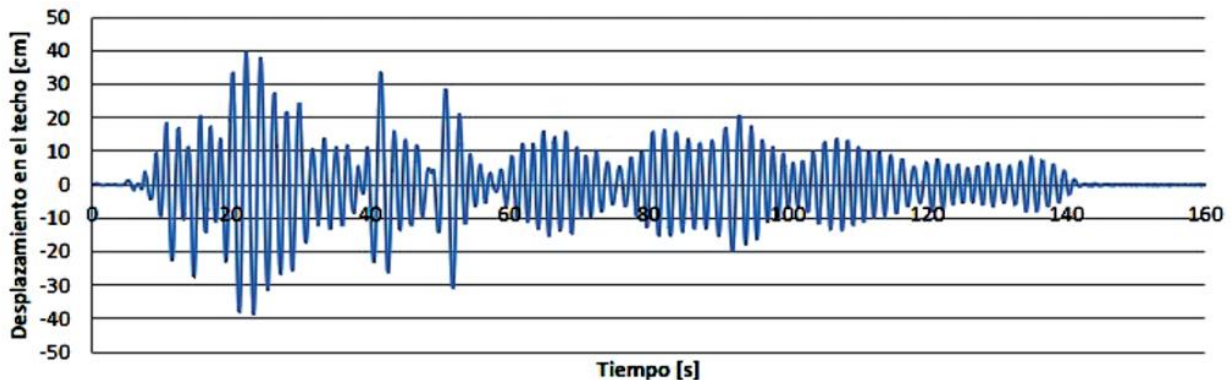

Figure 16. Lateral displacement history in the roof for structure with hybrid joints.

As shown in Figure 16, it is noted that the displacement of the structure on the roof is about 40 cm, slightly higher than that of traditional structures. However, there will be no related structural damage, and the structure will be restored to its original position without residual deformation, clearly reflecting the advantages of the proposed system. This is possible because the remaining structural elements are designed according to capacity to ensure the formation of the required collapse mechanism. In addition, Figures 17 and 18 show some bending moment angle diagrams obtained at the mixed connections of columns and beams, respectively.

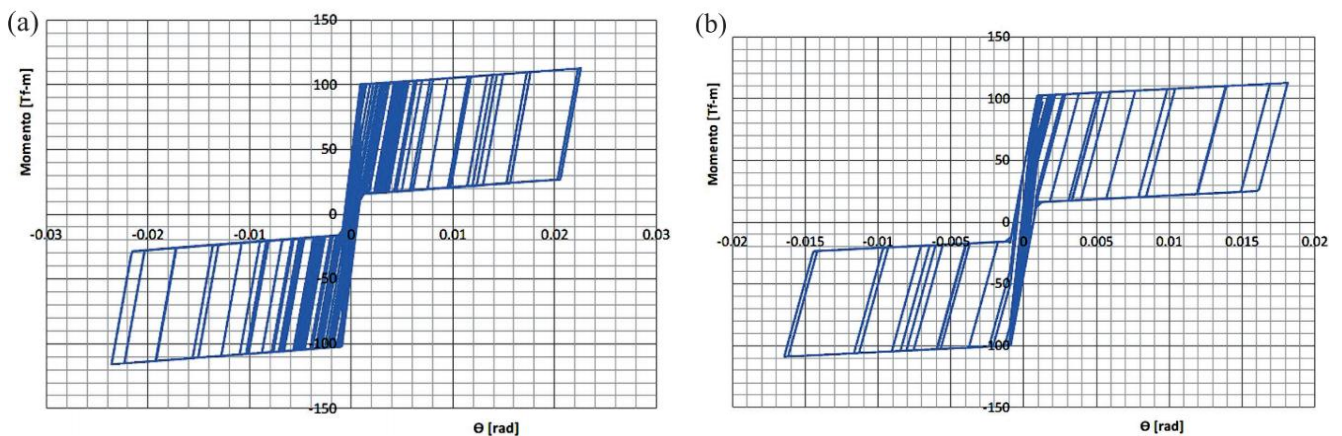

Figure 17. Moment-rotation diagrams for a column with hybrid connections, a) Lower end and b) Upper end.

From Figure 18, it can be seen that precast beams do not enter the nonlinear range, remaining elastic during the earthquake. However, they must have adequate strength so that the nonlinearity is concentrated in the hybrid connection of the columns. Figure 19 shows the required flexural strength scheme for the beams to remain elastic in the sections near the nodes.

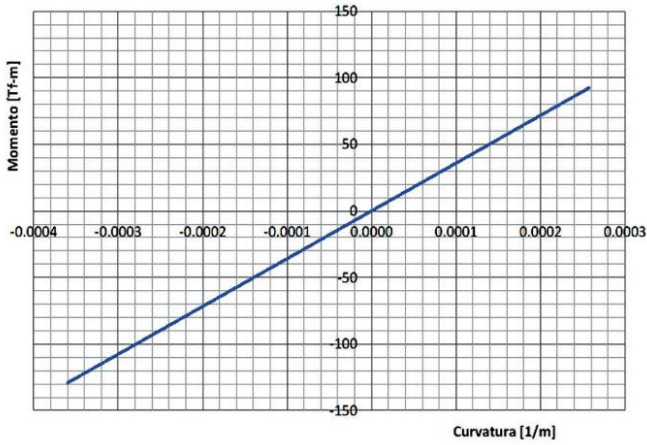

Figure 18. Moment-curvature diagram at right end of constant inertia precast beam.

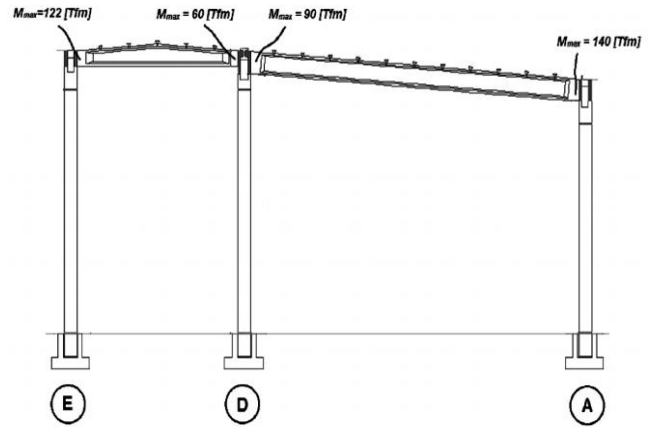

Figure 19. Required strength of beams in bending to remain elastic.

3.3 Model with hybrid joints for other seismic records

To compare the corresponding displacement requirements recorded under different soil conditions, the response of modified structures with mixed joints was obtained using the seismic records from Concepción and Vina del Mar. Figure 20 summarizes the key results obtained from the analysis. In blue, the response torque for the rotation of the bottom joint of the A-axis column exposed to the 2010 Concepción earthquake recording is depicted. The maximum torque and rotation values observed during the analysis using other seismic records are indicated on this curve. It can be seen that for the different records under consideration, the demand for deformation capacity varies due to the different soil conditions beneath the structure. In all cases, except for direct measurements taken on the rock surface, the available strength was reached, indicating that seismic design is primarily a displacement issue rather than a resistance issue.

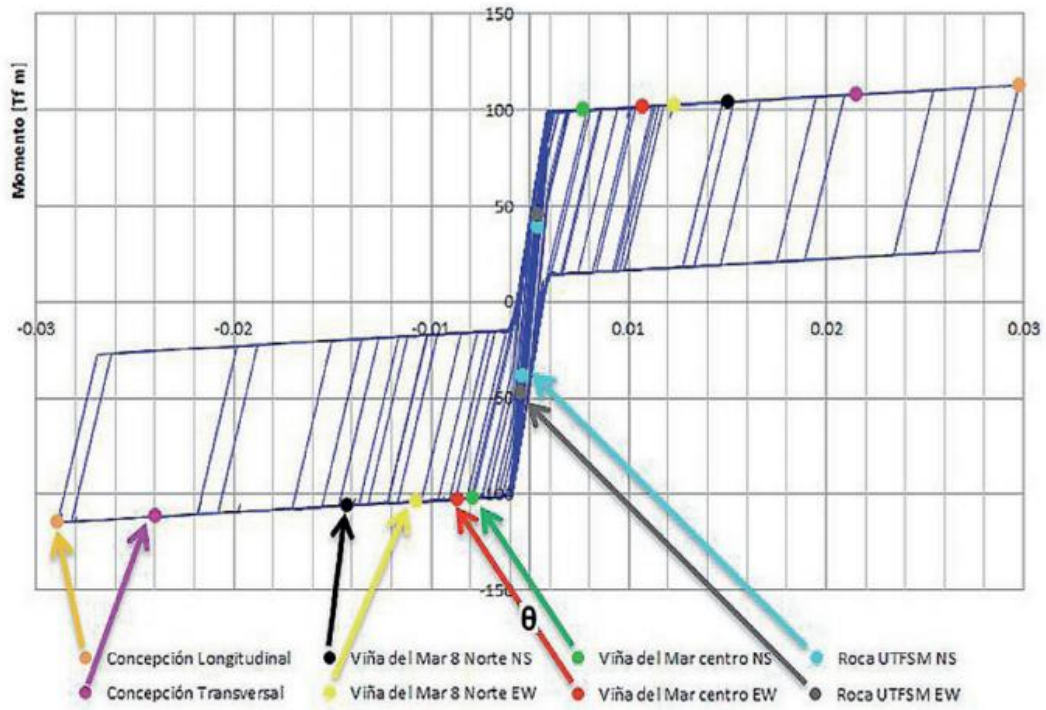

Figure 20. Hybrid joint moment-rotation diagram at the base of the A-axis column for various seismic records.

4. Conclusions

This research analysis indicates that using self-centering hybrid joints as a means of controlling seismic damage in prefabricated reinforced concrete gantry structures is effective. When the structure is located in loose sandy soil and there is a possibility of lateral seismic displacement of about 40 cm, this constructive solution becomes even more important. By comparing the seismic performance of traditional design gantry cranes with that of hybrid connection design gantry cranes, it can be emphasized that the latter can control the collapse mechanism, keep the beam elastic, concentrate damage at the opening of the hybrid connection in the column, dissipate this energy through ductile rods, and provide self-centering through post-tensioning cables. These comparative advantages are difficult to achieve in traditional force-based gantry designs. From a constructive perspective, it is possible to implement this hybrid connection system in actual industrial structures. Due to their need for continuity of operation, these structures need to minimize damage and limit residual deformation in the event of major seismic events.

Acknowledgments

The authors are grateful for the information and contributions to this article provided by engineers Manuel Robles (in charge of the design of the prefabricated structure) and Patricio Bonelli (structural seismic reviewer of the project, who suggested and advised on the design of the hybrid connections). Alexander Opazo, professor at the Universidad del Bío Bío, who collaborated in the drafting of this document, and the construction companies Prefabricados Estructurales S.A. (prefabricated elements manufacturing) and CME (field erection), for their important efforts and support during site visits, are also gratefully acknowledged.

Conflicts of Interest

The author declares no conflicts of interest regarding the publication of this paper.

References

- [1] ACI T1.2-03. 2003. Special hybrid moment frames composed of discretely jointed precast and post-tensioned concrete members. American Concrete Institute and Innovation Task Group 1 and Collaborators, Farmington Hills, MI.
- [2] Arslan, M.H., Korkmaz, H.H. and Gulay, F.G. 2006. Damage and failure pattern of prefabricated structures after major earthquakes in Turkey and shortfalls of the Turkish Earthquake code. *Engineering Failure Analysis*, 13(4), 537-557.
- [3] Boroschek, R., Soto, P. y Leon, R. 2010. Registros del terremoto del Maule Mw = 8.8, 27 de febrero de 2010. Red Nacional de Acelerógrafos, Universidad de Chile, Informe RENADIC 10(05).
- [4] Buchanan, A.H., Bull, D., Dhakal, R.P., MacRae, G., Palermo, A. and Pampanin, S. 2011. Base isolation and damage-resistant technologies for improved seismic performance of buildings. Royal Commission of Inquiry into Building Failure Caused by the Canterbury Earthquakes. University of Canterbury.
- [5] Carr, A.J. 2004. Ruaumoko 2D-Inelastic dynamic analysis. Department of Civil Engineering, University of Canterbury, Christchurch.
- [6] Celik, O. and Sritharan S. 2004. An evaluation of seismic design guidelines proposed for precast concrete hybrid frame systems. Iowa State University.
- [7] Clough, R.W. 1966. Effect of stiffness degradation on earthquake ductility requirements. Internal Report, University of California, Berkeley.
- [8] Kam, W.Y., Pampanin, S., Dhakal, R.P., Gavin, H., and Roeder, C.W. 2010. Seismic performance of reinforced concrete buildings in the September 2010 Darfield (Canterbury) earthquakes. *Bulletin of the New Zealand Society of Earthquake Engineering*, 43(4), 340-350.

- [9] Kam, W.Y., Pampanin, S. and Elwood, K. 2011. Seismic performance of reinforced concrete buildings in the 22 February Christchurch (Lyttleton) earthquake. *Bulletin of the New Zealand Society of Earthquake Engineering*, 44(4), 239-279.
- [10] Pampanin, S. 2005. Emerging solutions for high seismic performance of precast/prestressed concrete buildings. *Journal of Advanced Concrete Technology*, 3(2), 207-223.
- [11] Posada, M. and Wood, S. 2002. Seismic performance of precast industrial buildings in Turkey. In 7th US National Conference on Earthquake Engineering (7NCEE).
- [12] Priestley, M.J.N. 1991. Overview of the PRESSSS research programme. *PCI Journal*, 36(4), 50-57.
- [13] Priestley, M.N. 1996. The PRESSSS program: current status and proposed plans for phase III. *PCI Journal*, 41(2), 22-40.
- [14] Priestley, M.J.N., Sritharan, S., Conley, J.R. and Pampanin, S. 1999. Preliminary results and conclusions from the PRESSSS five-story precast concrete test building. *PCI Journal*, 44(6), 42-67.
- [15] Saatcioglu, M., Mitchell, D., Tinawi, R., Gardner, N. J., Gillies, A. G., Ghobarah, A. and Lau, D. 2001. The August 17, 1999, Kocaeli (Turkey) earthquake damage to structures. *Canadian Journal of Civil Engineering*, 28(4), 715-737.
- [16] Sezen, H. and Whittaker, A.S. 2006. Seismic performance of industrial facilities affected by the 1999 Turkey earthquake. *Journal of Performance of Constructed Facilities*, 20(1), 28-36.
- [17] Sharpe, R. 1974. The seismic response of inelastic structures. PhD thesis, Department of Civil Engineering, University of Canterbury.
- [18] Stanton, J., Stone, W.C. and Cheok, G.S. 1997. A hybrid reinforced precast frame for seismic regions. *PCI Journal*, 42(2), 20-32.
- [19] Thiers, R. 2014. Daños en edificios de hormigón armado y su relación con el suelo - Terremoto de Chile 2010. Tesis de Magister, Universidad Técnica Federico Santa Maria.
- [20] Zhao, B., Taucer, F. and Rossetto, T. 2009. Field investigation on the performance of building structures during the 12 May 2008 Wenchuan earthquake in China. *Engineering Structures*, 31(8), 1707-1723.