

Advances in Targeted Therapy of Non-small Cell Lung Cancer with EGFR Combined With P53 Gene Mutation

Di Lu¹, Yueyong Li^{2*}, Ju Liao¹, Wenxian Lin¹, Xiuli Mao¹, Xinxin Wei¹, Xiaohong Qin¹

¹ Youjiang Medical University for Nationalities, Baise 533000, Guangxi, China

² Affiliated Hospital of Youjiang Medical University for Nationalities, Baise 533000, Guangxi, China

DOI: 10.32629/jcmr.v5i2.2316

Abstract: Non-small cell lung cancer (NSCLC) is currently the leading cause of cancer death worldwide. NSCLC patients with epidermal growth factor receptor (EGFR) mutations were treated with EGFR-tyrosine kinase inhibitor (TKI), but EGFR mutations combined with other genes had a shorter survival. However, the P53 gene mutation is a common combined mutation in patients with NSCLC with EGFR gene mutation. This review summarizes the development of targeted NSCLC for EGFR with P53 mutations.

Keywords: non-small cell lung cancer; epidermal growth factor receptor; P53 gene

1. Introduction

1.1 EGFR gene mutation

EGFR is a transmembrane glycoprotein composed of 1186 amino acids, widely distributed on the surfaces of mammalian epithelial cells, fibroblasts, glia, keratinocytes, and is the driver gene [1] for the development of NSCLC. After extracellular epidermal growth factor signal activation receptor makes EGFR ligand dimerization, intracellular tyrosine kinase phosphorylation, acidified tyrosine exposure binding site and combined with intracellular signaling protein, form signaling protein complex, activate signaling protein, and further activate mitogen-activated protein kinase (MAPK), Akt, c-Jun amino-terminal kinase (JNK) and other downstream pathways, regulate cell proliferation, survival, migration and angiogenesis process. After EGFR gene mutation in NSCLC patients, it can independently constitutively activate signals through EGFR ligand and continuously activate EGFR pathway. Continuously activated EGFR pathway can promote tumor cell proliferation, tumor cell vascularization, tumor cell metastasis, and enhance tumor cell resistance to death.

1.2 The NSCLC signaling pathway process caused by the EGFR gene mutation

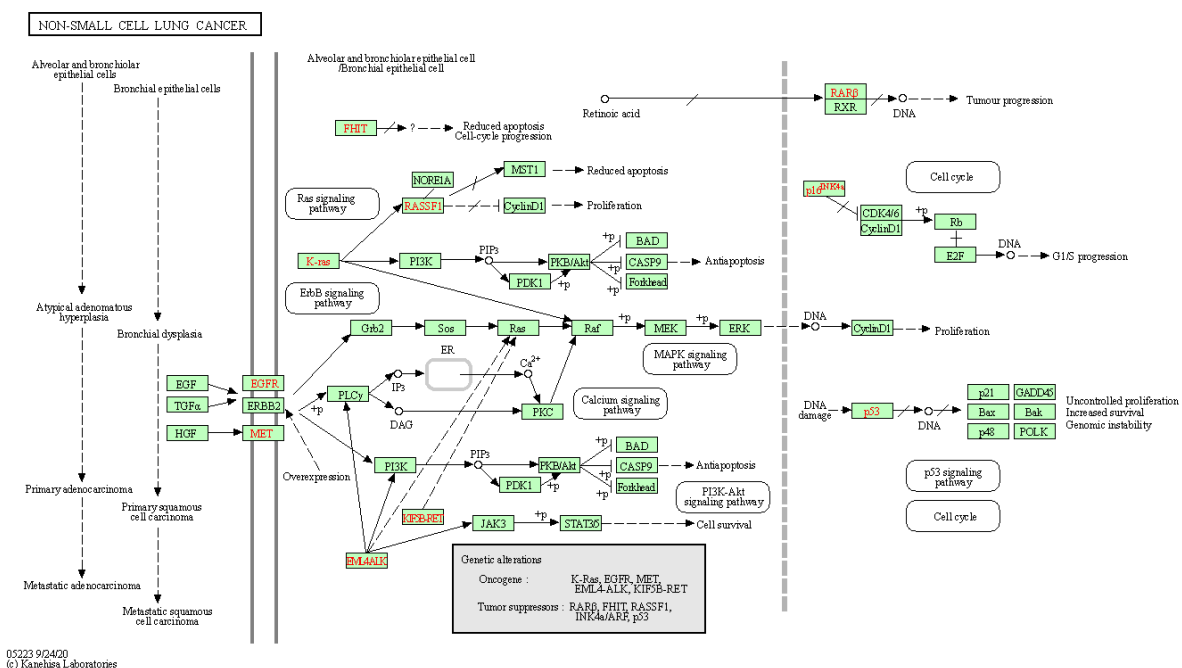

Figure 1. NSCLC signaling pathway caused by EGFR gene mutation

From Figure 1 we can see that the EGFR gene suppresses the expression of G1 / S-specific cyclin-D1 during DNA replication via the MAPK signaling pathway, thereby inhibiting cell proliferation. EGFR mutation can inhibit MAPK signaling pathway to promote the expression of G1 / S-specific cyclin-D1 in the process of DNA replication, promote cell proliferation and cause cell carcinogenesis; DNA damage is one of the reasons for the mutation of p53 gene. Since p53 is a tumor suppressor gene, its tumor suppressor function is changed and cannot inhibit cell carcinogenesis, thus causing uncontrollable cell proliferation and growth, namely cell carcinogenesis.

2. Analysis and discussion

2.1 The relationship between the P53 mutations and the EGFR mutation

In mutated late NSCLC, about 50% to 60% incorporated P53 mutant [2]. EGFR overexpression or signaling pathway activation caused by p53-based mutations plays an important role in tumorigenesis, and some studies have shown that certain GOF (gain-of-function) P53 mutations can promote the expression of EGFR by directly or indirectly activating the transcription promoter of the EGFR gene [3-4]. GOF is able to promote tumor invasion, growth and metastasis through numerous mechanisms, while also associated with drug resistance during tumor treatment. Dong et al found that GOF P53 could activate EGFR and related pathways and promote the invasive phenotype of endometrial cancer cells [5]. Lakoduk et al also found that the GOF P53 mutation allowed EGFR on the cellular membrane not to enter intracellular degradation and recirculate to the cell membrane [6], thus enhancing the migration and invasion ability of tumor cells [7]. In their study, Vokes et al. found that P53 can promote the evolution of tumor resistance to TKI, and this phenomenon is due to the reduction of P53 mutation in genome stability and then improve the potential of tumor cell gene mutation [8].

2.2 Treatment of EGFR with P53 gene mutation NSCLC

Currently, the treatment of EGFR patients with P53 gene mutation NSCLC is still in clinical trials. It has been shown that exon 8 mutations in the P53 gene have adverse effects on the prognosis of patients with NSCLC mutations in the EGFR gene treated with the first and second generation TKI. Some studies have used liquid biopsy to analyze the resistance mechanism of EGFR gene mutation NSCLC patients treated with osimertinib (third-generation TKI), and found that a rare site mutation in the P53 gene can weaken the efficacy of osimertinib. Thus, the survival benefit of TKI treatment alone in EGFR patients with P53 gene mutant NSCLC is limited [9-10].

2.3 TKI in combination with angiogenesis inhibitors

Schwaederle et al. reported that P53 gene mutation in NSCLC patients with EGFR gene mutation was associated with upregulation of the expression of vascular endothelial growth factor (VEGF)-A, and PFS (progression-free survival time) was prolonged in patients with P53 gene mutation compared with P53 wild type. Wheler et al confirmed that NSCLC patients with EGFR with P53 gene mutation could benefit from antiangiogenic therapy. A multicenter, randomized, double-blind phase RELAY study enrolled patients with advanced NSCLC with the EGFR gene 19del or 21L858R mutations combined with mutations in the P53 gene [11]. The test group received wilotinib combined with the angiogenesis inhibitor trimovumab, The control group received erlotinib in combination with placebo, The results showed that PFS (18 months) in the EGFR gene 19del mutation was longer than the corresponding control group (9.9 months), The PFS (14.7 months) of the 21L858R mutation and P53 gene mutation was longer than the corresponding control group (10.8 months), It suggests that TKI combined with angiogenesis inhibitors can prolong the PFS in EGFR patients with NSCLC with P53 gene mutation. However, there are few studies on TKI combined with angiogenesis inhibitors in EGFR patients with P53 gene mutation NSCLC, and its role in improving patient prognosis needs further studies.

2.4 TKI combined chemotherapy

Zhang et al. divided elderly NSCLC patients with EGFR and p53 gene mutation into test group and control group, TKA, the control group only TKA, the control group showed that the PFS (16 months) and OS (22 months) were longer than the control group, and the incidence of leukopenia, anemia, thrombocytopenia, abnormal liver function, abnormal renal function, rash, diarrhea, oral ulcer compared with the control group. Moreover, the sample size of this study is small, and the therapeutic effect of TKI combined with chemotherapy in EGFR with p53 gene mutation NSCLC needs further study [12].

2.5 Immunotherapy in combination with chemotherapy

A phase II clinical study [13] included 40 patients with first and second generation EGFR mutation advanced TKI resistance, and received the programmed death receptor-1 inhibitor triprelimab combined with platinum-containing dual-drug chemotherapy, which showed that the objective response rate of EGFR with p53 mutation was significantly higher (62%)

than p53 wild-type patients (14%), and immunotherapy combined with chemotherapy could be considered as subsequent treatment for EGFR patients with p53 mutation advanced NSCLC.⁴

3. Conclusion and outlook

The application of TKI improved the prognosis of patients with EGFR mutant NSCLC, but the prognosis of EGFR patients with P53 mutated NSCLC was poor, and the mechanism may be related to the development of small cell lung cancer transformation. At present, the study of EGFR with P53 gene mutation NSCLC treatment are small sample size, retrospective study, whether the combined application of angiogenesis inhibitors, chemotherapy, immunotherapy can make the survival benefit of EGFR with NSCLC patients with P53 gene mutation, need further confirmed by large sample size and prospective study, and the adverse effects of combination therapy should also be closely observed. For EGFR patients with NSCLC and P53 gene mutation, multidisciplinary evaluation should be conducted and individualized precision treatment plan should be formulated.

Acknowledgments

①Fund project name: High level Talent Research Project of the Affiliated Hospital of Youjiang Medical University For Nationalities (20212601); Subject name: The role and mechanism of p62/SQSTM1 protein in the tumor microenvironment after interventional embolization of liver cancer (Project leader: Yueyong Li).

②Fund project name: Project of Baise City Science Research and Technology Development Program (202241062022); Subject name: The mechanism of action of p62 protein in the dysregulation of tumor autophagy after BLBC: B-phase interventional embolization in primary liver cancer (Project leader: Yueyong Li).

③Fund project name: Development and promotion of suitable medical and health technologies in Guangxi (S2022140); Subject name: The mechanism of action and promotion of p62/SQSTM1 protein in tumor recurrence and metastasis after TACE in primary liver cancer (Project leader: Yueyong Li).

References

- [1] Wu Ning, Cheng Guanghui, Han Dongmei, et al. Experimental study of two-component targeted adenovirus vector targeting EGFR to mediate wild-type p53 and endostatin dual gene combined radiotherapy in non-small cell lung cancer [C]. 2016:518-518.
- [2] Passaro A, Attili I, Rappa A, et al. Genomic characterization of concurrent alterations in non-small cell lung cancer (NSCLC) harboring actionable mutations[J]. *Cancers (Basel)*, 2021, 13(9): 2172.
- [3] Vaughan CA, Pearsall I, Singh S, et al. Addiction of lung cancer cells to GOF p53 is promoted by up-regulation of epidermal growth factor receptor through multiple contacts with p53 transactivation domain and promoter[J]. *Oncotarget*, 2016, 7(11): 12426-12446.
- [4] Wang W, Cheng B, Miao L, et al. Mutant p53-R273H gains new function in sustained activation of EGFR signaling via suppressing miR-27a expression [J]. *Cell Death Dis*, 2013, 4(4): e574.
- [5] Zhang C, Liu J, Xu D, et al. Gain-of-function mutant p53 in cancer progression and therapy [J]. *J Mol Cell Biol*, 2020, 12(9): 674-687.
- [6] Dong P, Xu Z, Jia N, et al. Elevated expression of p53 gain-of-function mutation R175H in endometrial cancer cells can increase the invasive phenotypes by activation of the EGFR/PI3K/AKT pathway[J]. *Mol Cancer*, 2009, 8: 103
- [7] Lakoduk AM, Roudot P, Mettlen M, et al. Mutant p53 amplifies a dynamin-1/APPL1 endosome feedback loop that regulates recycling and migration[J]. *J Cell Biol*, 2019, 218 (6): 1928-1942
- [8] Vokes NI, Chambers E, Nguyen T, et al. Concurrent P53 mutations facilitate resistance evolution in EGFR-mutant lung adenocarcinoma[J]. *J Thorac Oncol*, 2022, 17(6): 779-792.
- [9] CANALEM, PETRACCI E, DELMONTE A. et al. Concomitant P53 mutation confers worse prognosis in EGFR mutated non-small cell lung cancer patients treated with TKIs [J]. *J Clin Med*, 2020, 9(4): 1047.
- [10] FUYL.WANGAQ.ZHOUIJQ: et al. Advanced NSCLC patients with EGFR T790M harboring P53 R273C or KRAS G12V cannot benefit from osimertinib based on a clinical multicentre study by tissue and liquid biopsy[J]. *Front Oncol* 2021.11:621992.
- [11] NAKAGAWAK, NADALEGARONE B. et al. RELAY subgroup analyses by EGFR Ex19del and Ex21L858R mutations for ramucirumab plus erlotinib in metastatic non-small cell lung cancer[J]. *Clin Cancer Res* 2021.27(19):5258- 5271
- [12] Zhang Chi, Shi Qingming, Gu Kangsheng. Clinical efficacy and safety of cream-directed + chemotherapy in elderly patients with EGFR + P53 [J]. *Chinese Journal of Gerontology*, 2022.42 (8): 1830-1832.
- [13] WIESTN, MAJEEDU, SEGOBINK. et al. Role of immune checkpoint inhibitor therapy in advanced EGFR-mutant non-small cell lung cancer[J]. *Front Oncol*. 2021.11:751209.